



History, Refined.

Owners Manual

68 Console



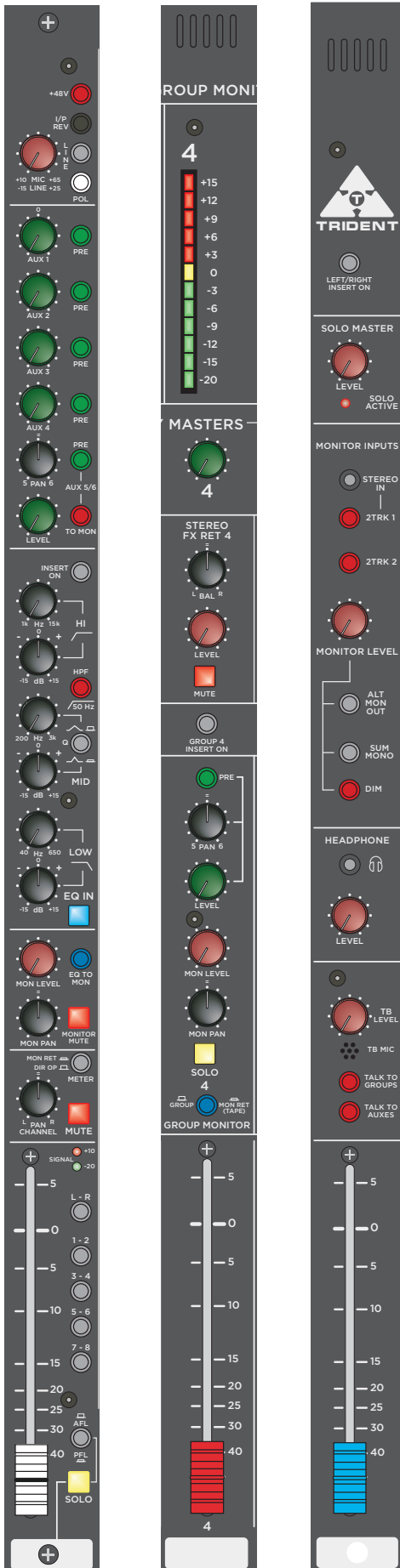

Table of Contents

Introduction/Specifications.....	3
Input Module.....	4
Group Module.....	10
Master Module.....	14
Rear Connections & Power Supply.....	17
DSub-25 Connector Pin Out.....	18
Warranty.....	19
Signal Flow Diagrams.....	20
Cautions.....	23
Fader Care & Maintenance.....	24
Recall Sheets.....	25
Project Sheets.....	28

Register your Trident 78 at

tridentaudiodevelopments.com/product-registration

Trident 68 Introduction & Specifications



The Series 68 analog consoles have been developed to deliver the core feature set most often needed for analog recording. The 68's are Split/Inline consoles with individual channels in 8-way panels. Using an 8 subgroup configuration and incorporating 6 Aux sends, its routing options are vast and simple to use. Connections are fast and easy with DB-25's throughout the board and XLR's for Master and Main outputs. With a flexible yet powerful 3 band EQ at its core, including selectable channel inserts and monolithic preamps driving the inputs, the Series 68 consoles offer a wide array of summing and mixing options. The sonic quality and compact footprint of the 68's are able to meet any demand.

Trident 68 Specifications

Input Impedance

Microphone: >2K Ω electronically balanced
Line: >10K Ω electronically balanced

Output Impedance

Left/Right, Monitor O/P, Group & Auxes <50 Ω
All other Outputs <100 Ω

Frequency Response

Mic Input to Mix Output <+0, -0.3dB 10Hz to 55KHz
@ 6-60 dB gain.
Line Input to Mix Output <0, -0.3dB <100Hz to 60KHz
@ 0 dB gain.

Distortion/Noise (T.H.D +Noise) at +15dBu Output

Mic XLR Input to any Output (-20dBu input) <0.003%
Line Input to any Output <0.003%
Monitor/Tape Return Input to any Output <0.003%

Noise

Mic EIN (20-20KHz, 150 Ω source, 60dB gain) <-128 dBu
Stereo residual Bus Noise (Output fader at min) <-95 dBu
Stereo Bus Noise (40 inputs continually assigned) <-80 dBu
(24 Input Mon/Tape Returns, 8 Stereo EFX Returns and 8 Master Tape Returns)

Bus Noise (24 inputs routed equiv. to 72 Inputs) <-75 dBu

Crosstalk

Adjacent Channel: <-90dB (@20KHz)
<-110dB (@1KHz)

Channel Fader Mute <-100dB (20Hz to 20KHz)
Monitor/Tape Return Mute <-85dB (20Hz to 20KHz)
Mix/Bus Assign <-80dB (20Hz to 20KHz)
Aux to Aux <-75dB (20Hz to 20KHz)

Maximum Input

Mic (XLR) Input (at min gain +10dB) +10dBu
Line (at min gain -15dB) +37dBu
All Monitor Returns +22dBu
All Insert Returns +22dBu

Maximum Output

Mix, Group, Aux, Monitor Outputs +26.5dBu (Into 600 Ω)
Channel Send/Direct Out +22dBu (Into 2K Ω)

Phase

Mic Input to Direct Out +20° to -1° 20Hz to 20KHz
Mic In to Mix Output +23° to -12° 20Hz to 20KHz
Line In to Mix Output +13° to -15° 20Hz to 20KHz
Monitor/Tape Return to Mix Output +8° to -12° 20Hz to 20KHz

Trident 68 Dimensions

	Width	Depth	Height
16 Channel:	33.37" (84.759cm)	28.750" (73.025cm)	12.293" (31.224cm)
24 Channel:	43.37" (110.159cm)	28.750" (73.025cm)	12.293" (31.224cm)

Module width

Input Module (8 Channels): 9.980" (25.350cm)
Master Module: 1.230" (3.124cm)
Group Module (8 Channels): 9.980" (25.350cm)

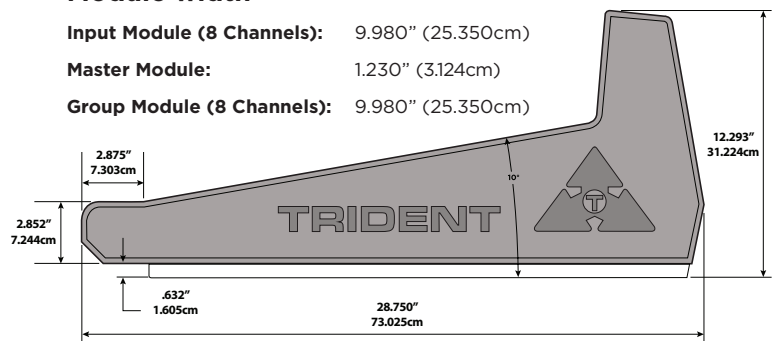

Trident 68 The Input Module

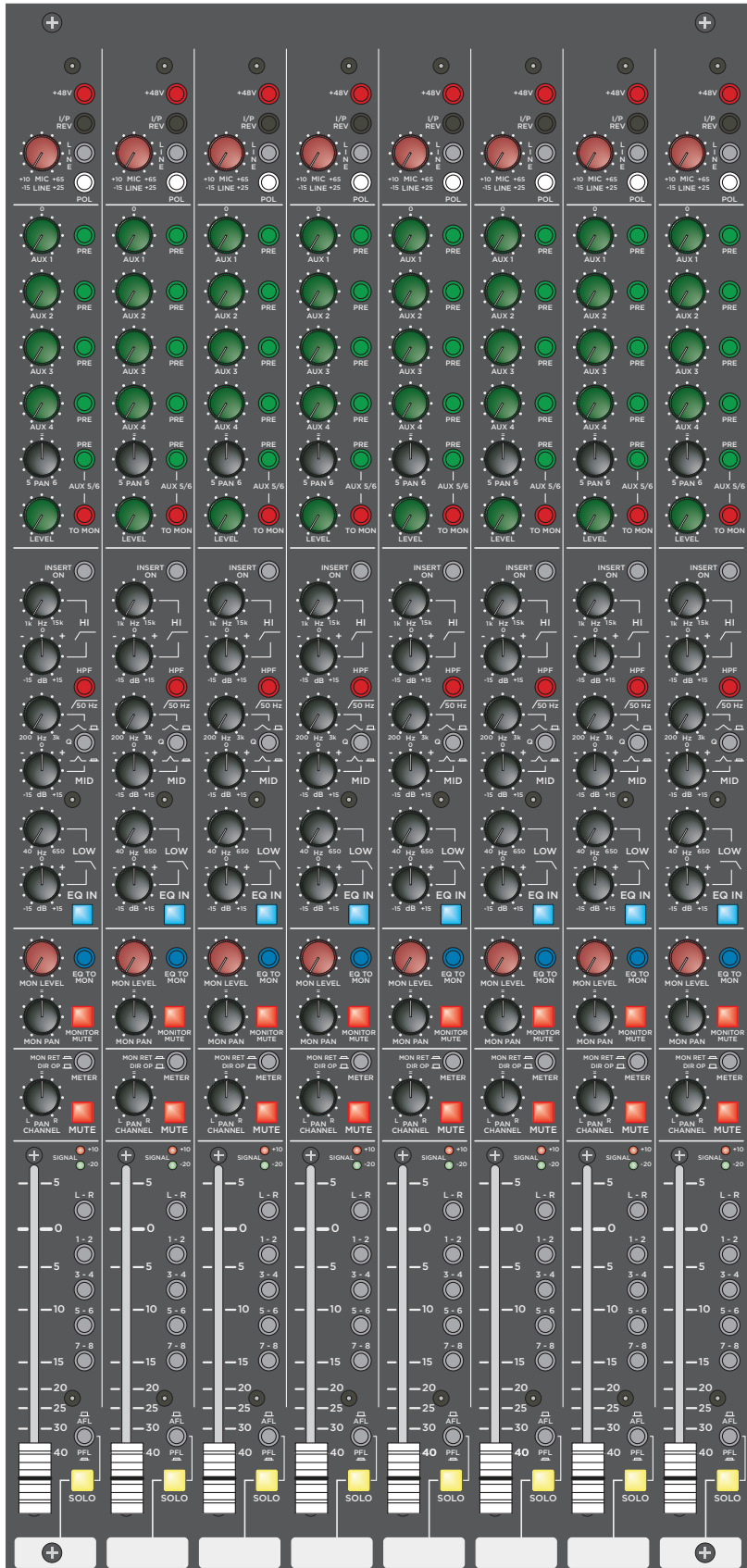

The Trident 68 Input module comprises of 8 equal Input channel strips, housed in a single metal front panel. Each channel offers multiple and flexible options for recording, mixing and monitoring multi-track recordings. Each Input module can easily be removed to from the top side of the console for service and further signal routing options.

The input is designed to accept both mic level and line level signals. It provides the user with a state of the art integrated microphone preamp. A three band Trident EQ is at the core of this console, comprising of variable high/low shelving and variable peaking mids with two bandwidth settings. Monitor Inputs are on every channel with the ability to swap the full EQ from the Input path to the Monitor path.

Access to the channel path is available through the means of a balanced insert located post equalizer, allowing the user to insert an effects device via the standard channel insert and to switch it in and out of the signal path via a top panel switch.

Six Auxiliary sends are provided, four mono and one stereo, each can be switched pre or post the channel fader. Aux 5/6 can also be selected between the channel and monitor path, greatly adding to the flexibility of the module.

Each module incorporates a monitor section which is used to monitor a replay channel from a multi-track recording device. This is in effect a separate signal path which ultimately feeds the master Left/Right main outputs. By switching the channel EQ and Auxiliary sends 5/6 to this path, this becomes an extremely versatile feature of the console. When monitoring the output of a multi-track recording device, it is possible to create a monitor mix with equalisation and reverb effects completely independently from the channel. These effects would also remain when the recording is played back through the same monitor section.

When the module is used for mixing purposes the monitor section functions as an additional line input return to the main Left/Right mix, this input has access to a stereo pair of auxiliary sends. This effectively doubles the number of inputs per input module that are available in mix down mode. This with additional inputs on the master section greatly increases the inputs available, even on the smallest console.

The input channel is provided with a switchable non destructive mono pre fader listen (PFL) and stereo after fader listen (AFL) SOLO system. It is possible then to hear the selected signal in isolation (or mixed with other "soloed" sources) separately in the main monitors, without effecting the main Left/Right mix.

The following gives a brief description of the controls on the Input module.

Trident 68 Input Channel Mic/Line Options

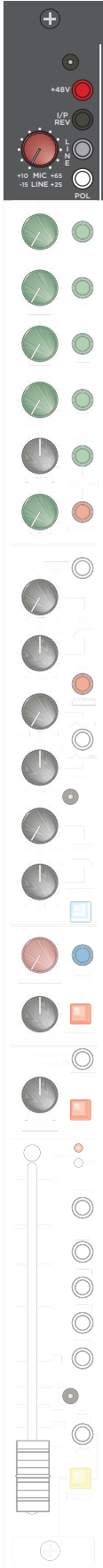

INPUT GAIN

This control adjusts the amount of gain of the signal from either the MIC or LINE (dependant on the LINE switch selection) connected to the associated input on the DSUB connector. For a low impedance balanced microphone plugged into the Channel the gain varies from +10dB min to approximately +65dB. With the Line switch depressed, this then controls the gain of the signal appearing on the associated line inputs. This gain varies between -15dB and +25dB.

POL

When depressed, reverses the electrical input polarity of any microphone or line level input signal selected as the channel source. Use of this control may alter the sound quality of a input relative to other channels when multiple microphones are picking up the same sound.

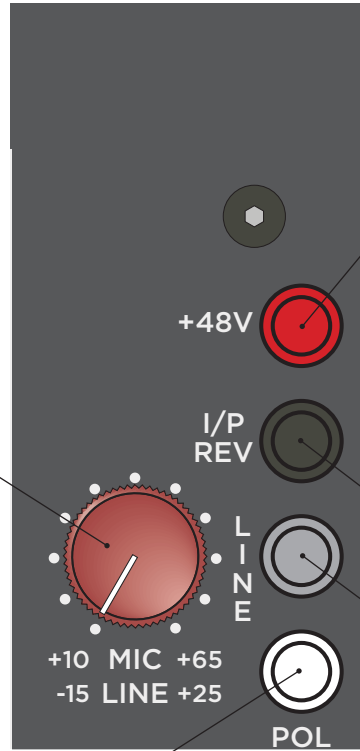

+48V

When depressed, provides +48 Volt phantom power to the balanced MIC inputs on the associated pins on the DSUB connector. Phantom power is required for operation of many condenser microphones. See your microphone instructions to see if phantom power is required or is to be defeated (some - though few - microphones require phantom power NOT to be activated or they may be damaged).

I/P REV

The Input Reverse switch when depressed flips the Line Input signal and the Monitor Input signals. In effect this switch determines the Line input source that is available to the channel. Combining this with the Line Switch above allows the user to source the channel signal from the associated channel Monitor Return pins of the DSUB connector and to use the full channel strip resources for the Monitor return signal. Alternatively depressing this switch selects the associated Line Input source for the channel Monitor section.

Line

Selects between the Channel Mic preamp signal (UP) or the signal appearing on the associated channel Line Input appearing on the DSUB connector (Down).

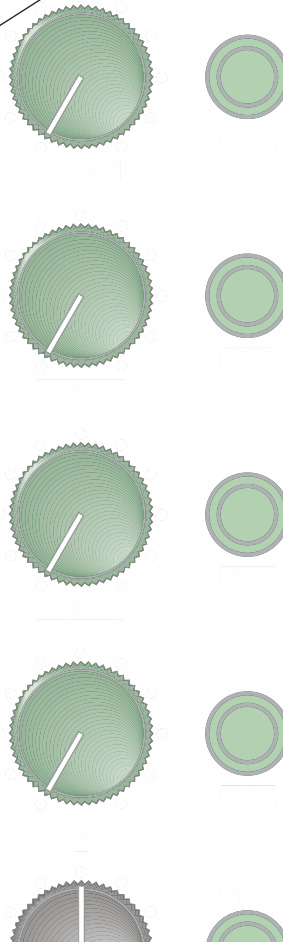

Trident 68 Input Channel Aux Sends

AUX 1 Level Control
Adjusts the mix level of Channel into the Aux 1 bus.

AUX 2 Level Control
Adjusts the mix level of Channel into the Aux 2 bus.

AUX 3 Level Control
Adjusts the mix level of Channel into the Aux 3 bus.

AUX 4 Level Control
Adjusts the mix level of Channel into the Aux 4 bus.

AUX 5-6 PAN Control
Adjusts the balance of the channel signal being fed to Aux 5 bus (CCW) and Aux 6 bus (CW). In the centre (=) position equal signal level is sent to both Aux 5 and Aux 6 buses.

AUX 5-6 Level Control
Adjusts the stereo mix level of Channel into the Aux 5 and Aux 6 buses.

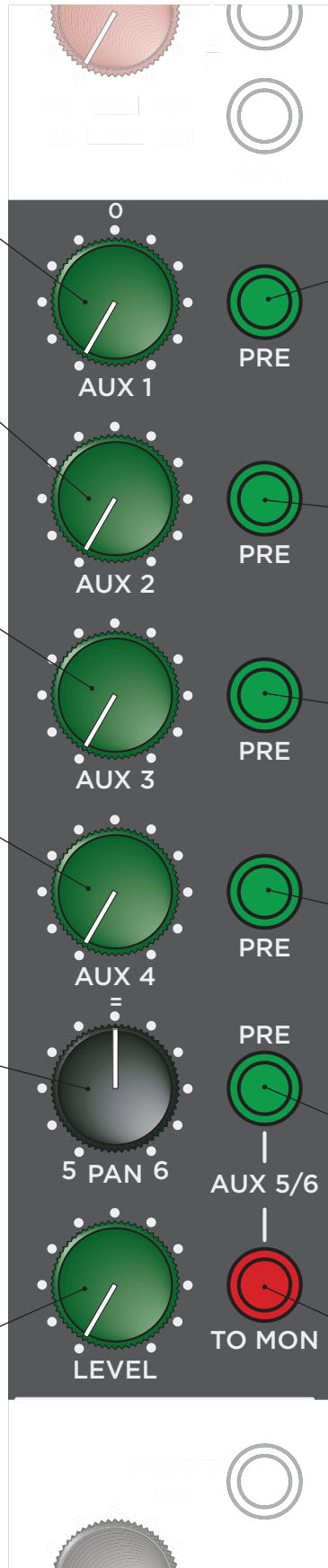

AUX 1 Pre Switch
This switch determines the signal source for Aux 1 bus, between Post (Up) or Pre (Down) Channel fader.

AUX 2 Pre Switch
This switch determines the signal source for Aux 2 bus, between Post (Up) or Pre (Down) Channel fader.

AUX 3 Pre Switch
This switch determines the signal source for Aux 3 bus, between Post (Up) or Pre (Down) Channel fader.

AUX 4 Pre Switch
This switch determines the signal source for Aux 4 bus, between Post (Up) or Pre (Down) Channel fader.

AUX 5-6 Pre Switch
This switch determines the signal source for Aux 5 and Aux 6 buses, between Post (Up) or Pre (Down) channel fader.

AUX 5-6 To Mon
When depressed selects the channel monitor input as the source to the Aux 5 - 6 Level control. In the up position sources the channel signal.

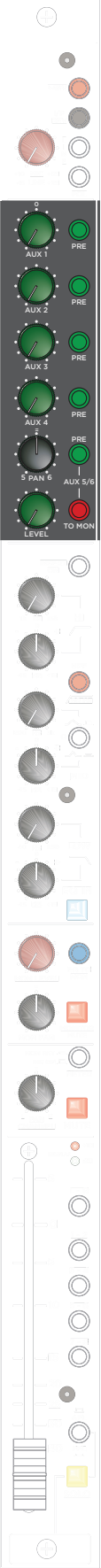

Trident 68 Input Channel Equaliser

Channel Equaliser

A three band Trident EQ with overlapping frequency ranges is provided along with a switchable high pass filter. The HIGH and LOW sections of the equaliser have a shelving response and the MID has a peaking (bell) response with two selectable bandwidth settings.

HIGH Frequency Section

Adjusts the high frequency shelving EQ response. The Level control adjusts the cut/boost between +/- 15dB of the selected "knee" frequency, this frequency is selectable between 1KHz and 15KHz. The centre "0" position of the Level control has a detent to indicate that it is having no effect on the associated channel signal. Cut or boost of the high frequency level control is usually used for minor tonal adjustments.

LOW Frequency Section

Adjusts the low frequency shelving EQ response. The Level control adjusts the cut/boost between +/- 15dB of the selected "knee" frequency, this frequency is selectable between 40Hz and 650Hz. The centre "0" position of the Level control has a detent to indicate that it is having no effect on the associated channel signal. Cut or boost of the low frequency level control is usually used for minor tonal adjustments.



INSERT ON

When depressed, this switch places the rear panel channel insert path to the Insert Send and back from the Insert Return in line with the signal path. This insert point by default is after the channel EQ. By routing the signal through this connector, the insert may be used for applications such as an effect that can be switched in/out. In the event the user wants to patch in his/her favourite external EQ, it can be connected with its input fed from the Insert Send and its output feeding the Insert Return, this path being activated with this switch. It could be used in conjunction with or without the Trident EQ.

HPF

When selected this applies a high-pass (or Low-Cut) filter with a corner frequency 50Hz and a roll off rate of 18dB per octave into the signal path. This control is used to remove unwanted signal content below 50Hz. The result is usually improved signal quality of the associated input signal while decreasing the low frequency amplification demand of the audio systems amplifier and speaker combination. Mainly for use with microphones, this helps remove low frequency rumble and handling noise.

MID Frequency Section

Adjusts the mid frequency EQ peaking response. The Frequency control selects the centre frequency of the filter (between 200Hz and 3kHz) and the Level control adjusts the cut/boost between +/- 15dB. The centre "0" position of the Level control has a detent to indicate that it is having no effect on this frequency band. The bandwidth of this filter is approximately one octave. With the addition of the Q switch, the bandwidth can be reduced to 1/3 octave. The high-mid frequency controls are used for minor tonal adjustment.

EQ IN

This switch inserts the 3-band EQ and High Pass Filter into the channel/monitor (see EQ TO MON switch description below) signal path. When not in use, it is suggested that the EQ be kept in the OUT position for best phase performance.



Trident 68 Input Channel Monitor Section

MONITOR LEVEL Control

Adjusts the monitor signal level to the Left/Right bus.

MON PAN (Monitor Pan) Control

This control blends the post monitor level signal between the Left and Right buses. When at the centre, detented position, both Left and Right buses are fed equal amounts of signal (each down by 3dB).

Channel PAN Control

This control blends the channel post-fader/post mute signal between any of the assigned bus pairs (L-R Mix, Group 1-2, Group 3-4, Group 5-6 and Group 7-8) located by the channel fader at the base of the module. When at the centre, detented position, both sides are fed equal amounts of signal (each down by 3dB).

EQ to MON

Assigns the 3 band channel EQ to the Monitor Section, removing it from the channel path.

METER

This button selects the signal that is fed to the relevant channel meter situated on the meter bridge. In the up position the Channel Direct Output feed is displayed.

[The Channel Direct Output can be user defined by a selectable option on the Input module, it can be selected either Channel post fader or Channel Insert Return (signal appearing on associated Channel Insert Return)].

When this button is depressed the channel meter is fed from the signal on the associated Channel MONITOR Input.

In a multi-track studio environment where the Channel Direct Output is fed to the recording device and the output of this device is connected to the MONITOR I/P, it is possible to see on the Channel meter what is sent to or received from the recording device.

MUTE (Channel)

When pressed will mute the assigned outputs of the channel (Group 1-8 and L-R Mix) and all post Aux sends. The Mute does not affect the channel's solo PFL feed, but WILL affect the channel metering in the Meter Bridge, the Direct Output of the channel (if selected as post fader by option on module) and the channel's solo AFL feed (which is post fader and post this mute).

Trident 68 Input Channel Group Assignment

Channel Signal Indicators

+10 - Indicates RED when the channel signal level has reached +14dBu (+10 VU)

-20 - Indicates GREEN when the channel signal level has reached -16dBu (-20 VU)

The channel indicator signal source can be selected pre or post the channel fader through an option available on the input module circuit board.

(Note: Signal headroom available on the input module is +22dBu and when the +10 indicator illuminates the signal level is approaching 6 to 8 dB before clipping when just flashing red with signal peaks).

These are extremely useful features and provide a constant indication that a signal is present in the module (green LED) and that the signal peak is being reached (red LED).

AFL/PFL Select

Selects the channel source feed that will be fed to solo bus when the Channel SOLO is pressed. UP - solo system is fed from the channel post fader/post pan pot point and is a stereo signal that follows the pan pot. This allows the user to monitor the channel in the solo system and to see its contribution to the mix.

Down - solo system is fed from the channel pre fader point and is a mono source. This allows the user to monitor the signal in the solo system before the channel fader/mute, allowing the user to check the signal in the channel without being routed to any output buses.

SOLO

When pressed, routes the channel AFL or PFL (see AFL/PFL Select above) signal to the Solo bus. Additionally this switches the Main Monitor Output (normally fed the Left/Right Mix) to source the signal from the AFL/PFL Master Level in the Master section as well as to trigger LED indicators in the Master section and Meter-Bridge stating a solo has been pressed.

BUS ASSIGNMENTS

Assigns the Channel post-fader signal to the Left and Right mix buses through the Channel Pan Control. With the Channel Pan control in mid position, the signal will be fed to Left and Right buses in equal amounts. If the Channel Pan Control is positioned fully anti-clockwise (left) the channel signal will only feed Left bus and when positioned fully clockwise (right), the signal will only feed Right bus.

Sometimes referenced as the Main mix or Remix bus assignment. In a multi-track studio environment, this L-R assignment and the Channel Monitor Input allow the user to have two separate external inputs (Channel Mic/Line and Monitor return) that can be sent to the Left and Right mix busses, effectively doubling your inputs on mixdown (Remix)

1-2 Group Assignment

Assigns the Channel post-fader signal to the Group 1 and 2 mix buses through the Channel Pan Control. With the Channel Pan control in mid position, the signal will be fed to Group 1 and 2 in equal amounts. If the Channel Pan Control is positioned fully anti-clockwise (left) the channel signal will only feed Group 1 and when positioned fully clockwise (right), the signal will only feed Group 2.

3-4 Group Assignment

Assigns the Channel post-fader signal to Group 3 and 4 mix buses through the Channel Pan Control. Operation is the same as the 1-2 Group assignment.

5-6 Group Assignment

Assigns the Channel post-fader signal to Group 5 and 6 mix buses through the Channel Pan Control. Operation is the same as the 1-2 Group assignment.

7-8 Group Assignment

Assigns the Channel post-fader signal to Group 7 and 8 mix buses through the Channel Pan Control. Operation is the same as the 1-2 Group assignment.

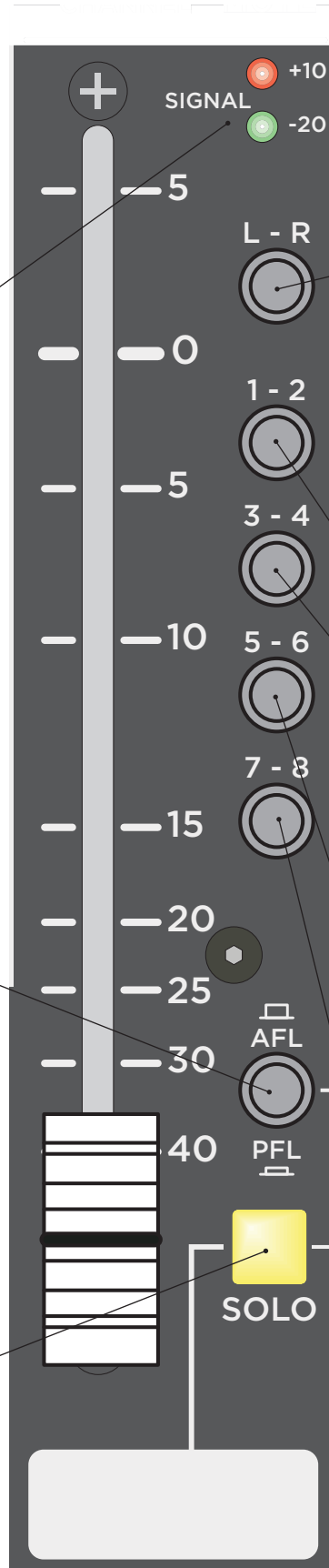
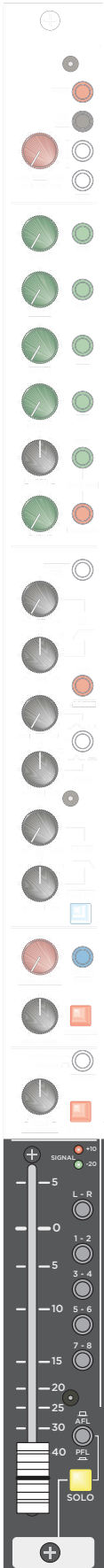

Trident 68 Group Module Section



The Group section of the console greatly enhances the flexibility of the TRIDENT 68 console and provides a number of different functions. There are 8 Group channels provided on the Group Module panel of the console, these are mounted on a single group strip controlling the associated group mix bus outputs. The groups can be used as audio subgroups for combining and processing a collection of input channels. Each group bus has its own balanced Insert Send/Return and Outputs that feed the associated DSUB connector on the rear Master Connector panel.

The Group module also provides a method of monitoring and panning the group output on the control room speakers. By using these controls it is possible to build up a monitor mix of the recorded tracks and any that are about to be recorded. To enhance this monitor facility Auxiliary sends 5 and 6 are available making it possible to send a headphone mix from the groups together with reverb and effects and since all Auxiliary sends are switchable to Pre the monitor level control, they can be used to create a separate auxiliary mix independent of the monitor level.

Individual monitor source switches (MONITOR RETURN) make it possible to select either the group output or the associated balanced line (Group Monitor Input) into the monitoring system. The 12 segment bargraph metering and Auxiliary sends follow this switch so that they automatically switch according to the position of the MONITOR RETURN switch.

Each of the 8 Group channels is also provided with a SOLO pushbutton. This makes it possible to listen to the signal on any selected Group in isolation and in stereo through the console's SOLO system. Since the SOLO function is post the Group MONITOR LEVEL control, this makes it possible to solo a number of Group channels and create a balanced mix of the soloed signals.

A separate facility on each Group channel is the inclusion of a stereo Effects Return Section.

Individual inputs are provided on the DSUB connector located on Master Connector panel and are wired in stereo and these feed the Effects Return section on the associated Group channel. This adds the ability to send a signal (from the EFX Return Inputs) with level and pan control to the master Left/Right mix.

The following gives a brief description of the controls on the Group module.

Trident 68 Group Metering Section



1

+15
+12
+9
+6
+3
0
-3
-6
-9
-12
-15
-20

1

12-Segment Bargraph Meter

Displays one of 2 sources as determined by the Monitor Return Switch below (MON SOURCE and AUX TO MTR). The meter is a peak responding meter with a fast attack and slower release. It is very useful when used with complex dynamic waveforms and able to display sharp transient responses and greatly assist the engineer when it comes to avoiding distortion during recording.

1

+15
+12
+9
+6
+3
0
-3
-6
-9
-12
-15
-20

1

AUX MASTER LEVEL

This control adjusts the Aux bus mix level that appears on the associated Aux Output pins of the DSUB on the rear panel.

NOTE: Since there are only Six Auxiliary sends on this console, this control is not available on Group channel strip 7 and 8.

A vertical strip of various controls including knobs, buttons, and a fader.

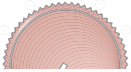

Trident 68 Group EFX RETURN Section

EFX LEVEL Control
Adjusts the Stereo Effects Return signal level to the Left/Right bus.

EFX RTN MUTE
When pressed will Mute the Effects Return signal to the Left/Right bus. It is recommended when the EFX RTN section is not being used that it be muted.

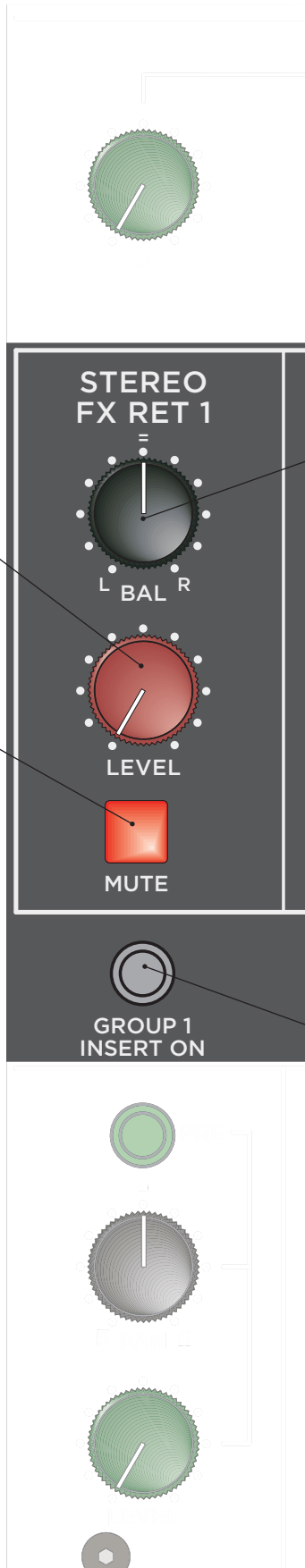

EFX RTN BAL Control
This control blends the stereo EFX post-level/post mute signal between the Left and Right buses. When at the centre detented position, both sides are fed equal amounts of signal (each down by 3dB).

GROUP INSERT ON
When depressed, this switch places the rear panel Group Insert path to the Insert Send and back from the Insert Return in line with the signal path. This insert is directly after the Group mix stage and before the Group Fader and allows the user to connect an external device in series with the Group signal and to be able to switch it in/out from the front panel.

Trident 68 Group Monitor Aux Sends



AUX 5-6 PAN Control

Adjusts the balance of the Monitor signal being fed to Aux 5 bus (CCW) and Aux 6 bus (CW). In the centre (=) position equal signal level is sent to both Aux 5 and Aux 6 buses.

AUX 5-6 Level Control

Adjusts the mix level of the Monitor Input into the Aux 5 and Aux 6 buses.

MONITOR PAN Control

This control blends the Monitor Input post-level/post mute signal between the Left and Right buses. When at the centre detented position, both sides are fed equal amounts of signal (each down by 3dB).

MONITOR RETURN (Source)

This switch determines the signal source to the Group Monitor section; additionally it displays the signal shown on the bargraph meter above. In the UP position the signal fed to the group Monitor section and bargraph meter is the Group output. When depressed (DOWN) the signal fed is derived from the associated rear MONITOR RETURN pins on the DSUB connector on the rear panel.

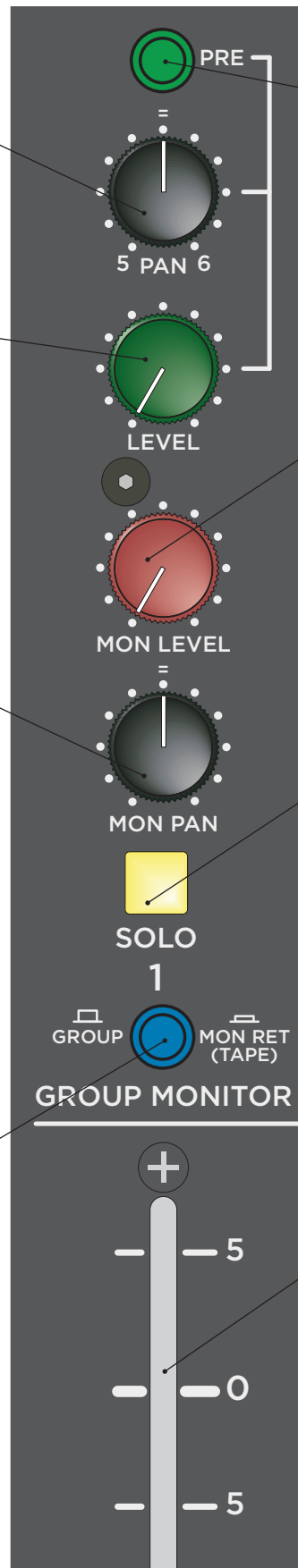

AUX 5-6 Pre Switch

This switch determines the signal source for Aux 5 and Aux 6 buses, between Post (Up) or Pre (Down) Monitor Level.

MONITOR LEVEL Control

Adjusts the Monitor input signal level to the Left/Right bus. It is recommended to keep this level at minimum when not in use to avoid unnecessary additional noise source to the Left/Right buses.

MONITOR SOLO (AFL)

When pressed, routes the Monitor signal (post level and pan) to the Solo bus. Additionally this switches the Main Monitor Output (normally being fed the Left/Right Mix) to source the signal from the AFL/PFL Master Level in the Master section as well as to trigger LED indicators in the Master section and Meter-Bridge stating a solo has been pressed.

GROUP FADER

Controls the associated Group Output level that feeds the balanced outputs on the Master Dsub panel as well as the signal fed to the monitor section when selected as the source.

Trident 68 Master Talkback Section

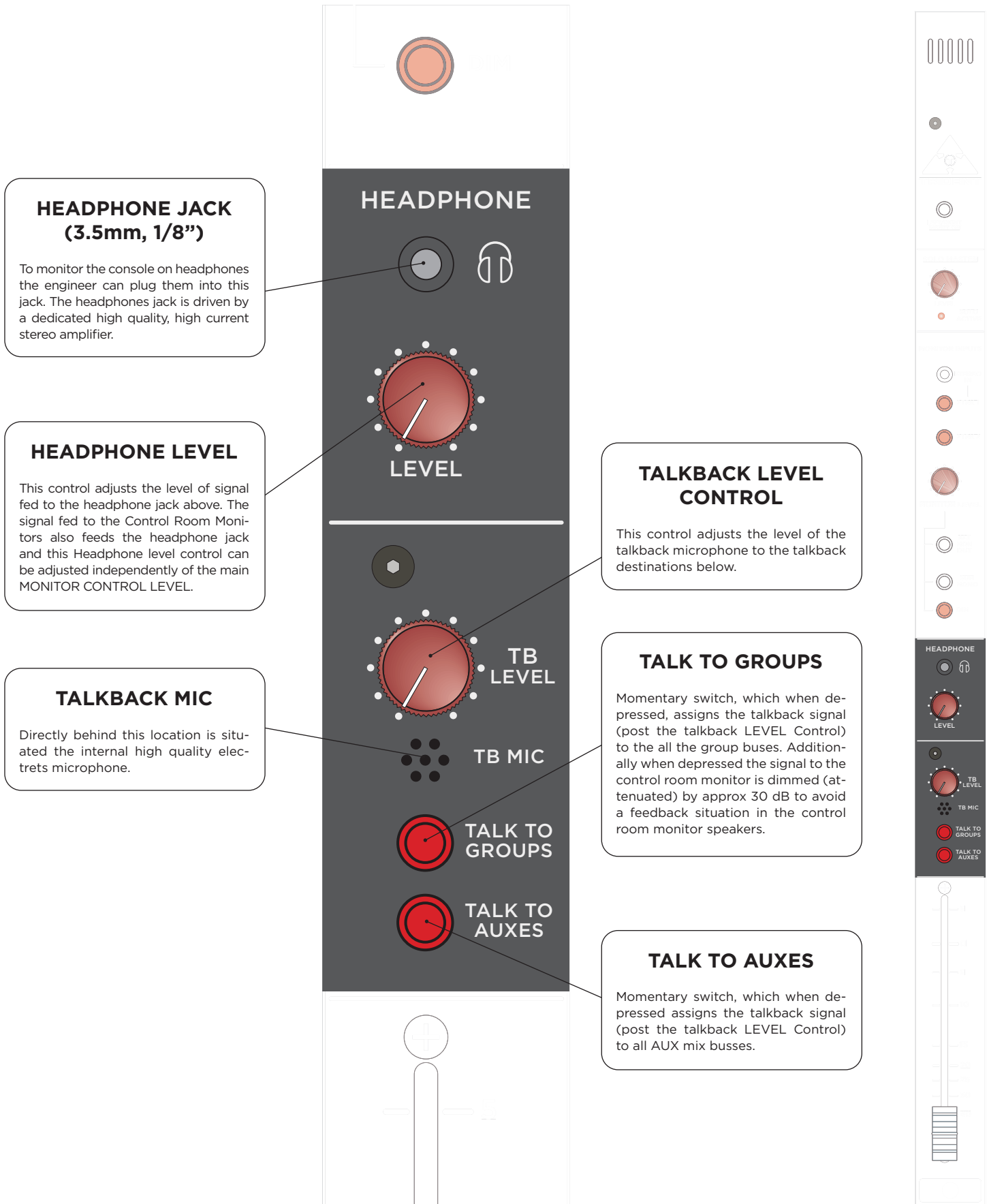

Trident 68 Rear Connections | Power Supply

Input Connector

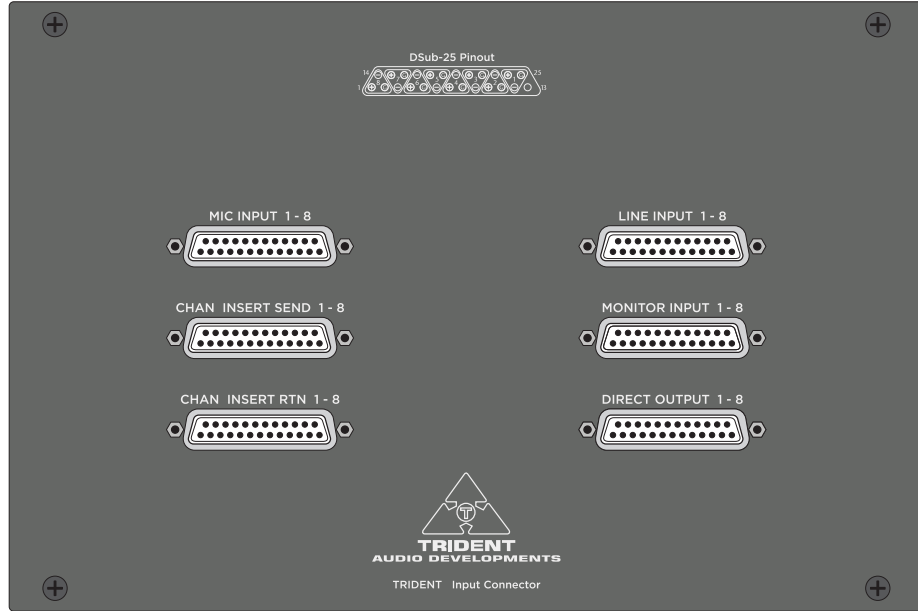

Master Connector

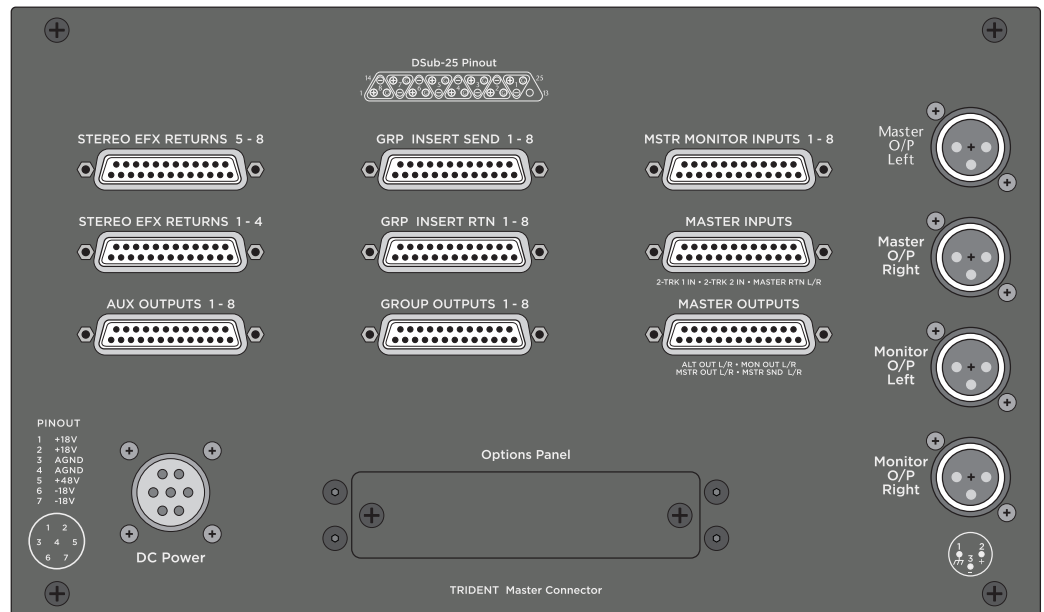

Power Supply

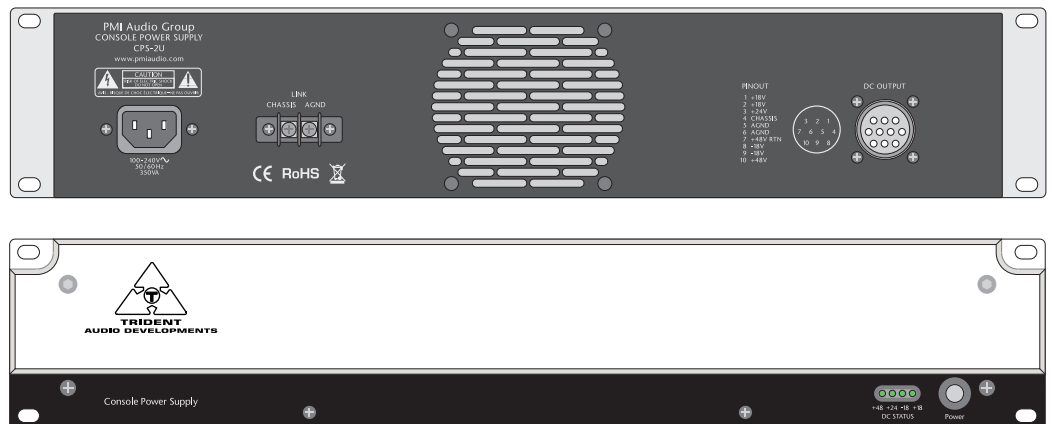

Trident 68 DSub-25 Pin Out

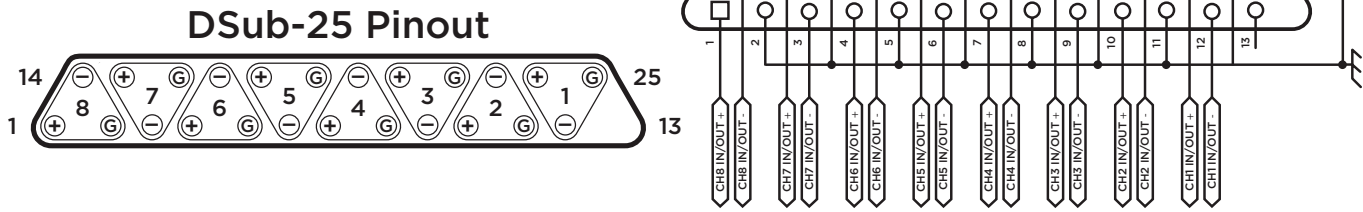

DSUB	Position							
	8	7	6	5	4	3	2	1
INPUTS								
Mic Input	Input 8	Input 7	Input 6	Input 5	Input 4	Input 3	Input 2	Input 1
Channel Send	Send 8	Send 7	Send 6	Send 5	Send 4	Send 3	Send 2	Send 1
Channel Return	Return 8	Return 7	Return 6	Return 5	Return 4	Return 3	Return 2	Return 1
Line Input	Input 8	Input 7	Input 6	Input 5	Input 4	Input 3	Input 2	Input 1
Monitor Input	Input 8	Input 7	Input 6	Input 5	Input 4	Input 3	Input 2	Input 1
Direct O/P	O/P 8	O/P 7	O/P 6	O/P 5	O/P 4	O/P 3	O/P 2	O/P 1
	8	7	6	5	4	3	2	1
MASTER								
Stereo EFX Returns 5 - 8	Stereo EFX Ret 8R	Stereo EFX Ret 8L	Stereo EFX Ret 7R	Stereo EFX Ret 7L	Stereo EFX Ret 6R	Stereo EFX Ret 6L	Stereo EFX Ret 5R	Stereo EFX Ret 5L
Stereo EFX Returns 1 - 4	Stereo EFX Ret 4R	Stereo EFX Ret 4L	Stereo EFX Ret 3R	Stereo EFX Ret 3L	Stereo EFX Ret 2R	Stereo EFX Ret 2L	Stereo EFX Ret 1R	Stereo EFX Ret 1L
Aux O/Ps	NC	NC	Aux 6	Aux 5	Aux 4	Aux 3	Aux 2	Aux 1
Group Send	Send 8	Send 7	Send 6	Send 5	Send 4	Send 3	Send 2	Send 1
Group Return	Return 8	Return 7	Return 6	Return 5	Return 4	Return 3	Return 2	Return 1
Group O/Ps	O/P 8	O/P 7	O/P 6	O/P 5	O/P 4	O/P 3	O/P 2	O/P 1
Group Monitor Input	Input 8	Input 7	Input 6	Input 5	Input 4	Input 3	Input 2	Input 1
Master Inputs	Ext Mic Input (for TR 78 only)	Spare	2TRK1 Right	2TRK1 Left	2TRK2 Right	2TRK2 Left	Master Right Return	Master Left Return
Master O/Ps	Alt Out Right	Alt Out Left	Mon Out Right	Mon Out Left	Master Right Out	Master Left Out	Master Right Send	Master Left Send

Trident 68 Warranty Information

Trident Audio Developments Limited Warranty Statement

The following outlines the warranty periods for The Trident 68 Analogue console. All extended coverage is based on the timely registration of said products within the 30 days of purchase to the original purchaser from the date of Proof Of Purchase. Proof of purchase is the original Bill Of Sale or Sales Invoice from an authorized dealer.

Inquire about extended warranty.

Trident Audio Developments is covered by a limited warranty against defects in materials and workmanship (parts and labor) for a period of Two (2) Years from the date the unit is sold to the Dealer or original purchaser only.

Receive an additional free year warranty covering parts and labor with the registration of your console!

Acceptable registration is met by filling out online the warranty registration, along with a copy of the original sales receipt as proof of the original date of purchase. tridentaudiodevelopments.com/product-registration

The terms and conditions of this limited warranty are:

1. The warranty applies to Trident Audio Developments purchased from Trident Audio or authorized Trident Audio dealers. The authorized dealers of Trident Audio products are listed at each brands websites, or on the main page at tridentaudiodevelopments.com
2. The warranty covers any defects in materials and workmanship, and is limited to the repair or replacement of the original registered product. In its sole discretion, Trident Audio may either repair or replace the product with a product of the same model, or replace the product with a new model of a similar specification, when the same model is no longer available.
3. The warranty does not cover any of the following: damage caused by the user; spillages or moisture damage; neglect, abuse or misuse, including but not limited to the failure to use the products for its normal purpose in accordance with the manufacturer's instructions for use, failure to properly maintain the product in accordance with the manufacturer's instructions, and/or the failure to use the products in accordance with the manufacturer's specifications; normal wear and tear; use of products with incompatible or faulty equipment; unauthorized modifications; repairs conducted by unauthorized persons or service center's; the model and/or serial number being altered, removed or made illegible; accidents; or acts of God or any cause beyond the control of Trident Audio.

It does not cover damage caused by connecting to improper power voltage supply, cosmetic defects, such as paint finish, and general wear and tear. All consumables items such as fuses, meter bulbs and component shelf life on pots, faders and switches are covered by a 90 day limited warranty. Products sold in AS IN, B Stock, or DEMO model condition are not covered.

4. The warranty is applicable to the original purchaser throughout the warranty period as stated above or until original owner resells product. If a unit is received for warranty repair, and after complete examination and testing, no problem is found with the unit, customer will be charged for time, labor, and return shipping costs, presuming initial user error falsely caused the unit to be determined faulty, or no fault was found.

5. The warranty does not affect any statutory rights the original purchaser may have in accordance with the law applicable in the jurisdiction where the product was purchased, or any rights the original purchaser may have against the authorized dealer pursuant to their original purchase agreement.

6. Any claim pursuant to this warranty from the date of purchase of any Trident Audio Developments product must be returned, together with the original proof of purchase, to the authorized Trident Audio reseller that sold the product, or to the Trident Audio service center in either the USA or the UK. All returns to Trident Audio, Trident Audio UK or any Trident Audio Service Center must be in the original packing, accompanied by the

issued Repair Authorization, and must be shipped to the address specified on the Return Authorization via insured freight at the customer's own expense. Factory original packaging can be ordered from Trident Audio if the original has been thrown away. Customer will be charged for new factory original packaging if customer fails to ship product to Trident Audio in the original factory packaging. Trident Audio will not pay for express or overnight or other special service delivery.

7. Once the product has been received, the authorized Trident Audio service center will assess the warranty claim and arrange to either repair or replace in accordance with the warranty procedure prescribed by Trident Audio for their authorized service center network. The warranty replacement will be conducted by the authorized Trident Audio service center as promptly as possible and within a reasonable time from the date of submission of the warranty claim pending pandemic conditions. In all circumstances, a claimant under this warranty will be liable for all costs in delivering their Trident Audio brand product to the authorized service center for warranty replacement, and for all costs in collecting the repaired/replacement Trident Audio product from that authorized Trident Audio service center no matter what the distance may be. Trident Audio service center may waive the cost of return shipping after full inspection to determine cause of warranty.

8. Trident Audio will not accept any warranty replacement without the original proof or purchase of the Trident Audio product, and without the registration of the Trident Audio product within 30 days of purchase by mail, or online. It is the original purchaser's responsibility to keep the original proof or purchase safe at all times, as Trident Audio is not obliged to provide a replacement of the original proof or purchase.

9. The warrantor assumes no liability for property damage, lost income, or any other incidental or consequential damage whatsoever which may result from failure of this product and it's use.

10. A Trident Audio product that was not purchased through an authorized and legitimate sales channel is considered "Grey Market". Warranties for Trident Audio Products purchased outside the USA will be covered by Trident Audio UK for that specific country or region, or by local Trident Audio distributors. Trident Audio product originally sold to the USA market and consequently resold overseas forfeits its warranty. American Trident Audio Dealers are forbidden to export Trident Audio Products. Non-American dealers are forbidden to export to the USA. "Grey Market" purchases are not covered by any warranty. In the case that a Trident Audio Product must be returned, it should be returned to the original place of purchase, or the Trident Audio factory, with proper return authorization. Returns from outside the USA, customer shall adhere to specific shipping, customs, and commercial invoicing instructions given with the Return Authorization. Trident Audio will not be responsible for transportation costs, Duties or customs fees related to any importation or re-exportation charges whatsoever.

11. Trident Audio shall not be liable for damages of the Trident Audio product arising out of the use or inability to use the Trident Audio product insofar as allowed to be disclaimed by law in the jurisdiction where the Trident Audio product was purchased.

Governing Laws

Any dispute, controversy or claim arising out of or relating to this Agreement shall be decided by arbitration in Los Angeles, California, in accordance with the rules of the American Arbitration Association (the "Association") then in effect. Any award rendered by the Association shall be final, binding and not subject to appeal, and may be enforced by any court of competent jurisdiction.

For Tech Support and Repair Authorisation, please contact:

US Service & Sales

1845 W. 169th Street Gardena, CA 90247
+1 (310) 323-9050
support@tridentaudiodevelopments.com

Trident 68 Input Module Flow Diagram

Trident 68 Input Flow Diagram

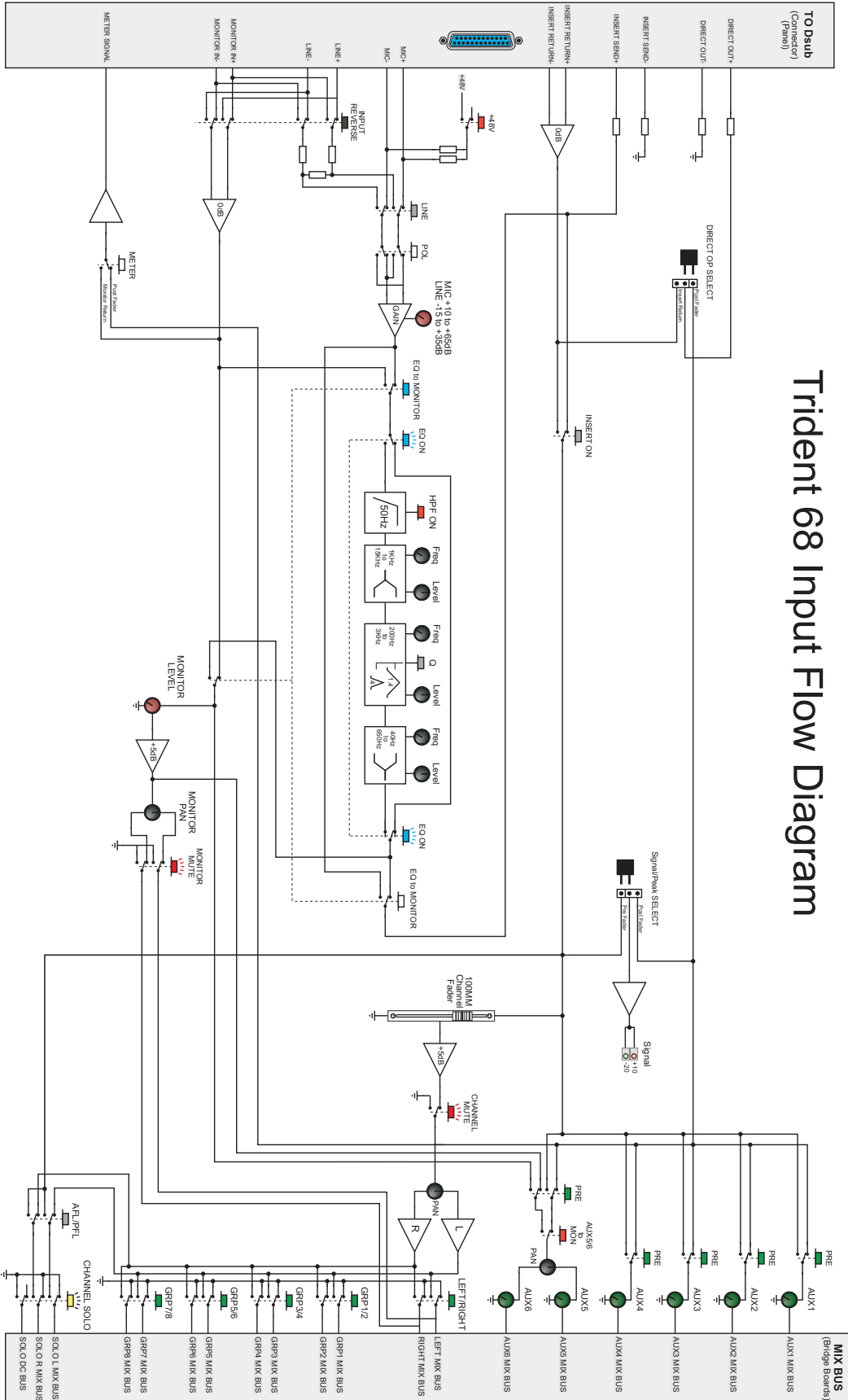

Trident 68 Group Module Flow Diagram

Trident 68 Group Flow Diagram

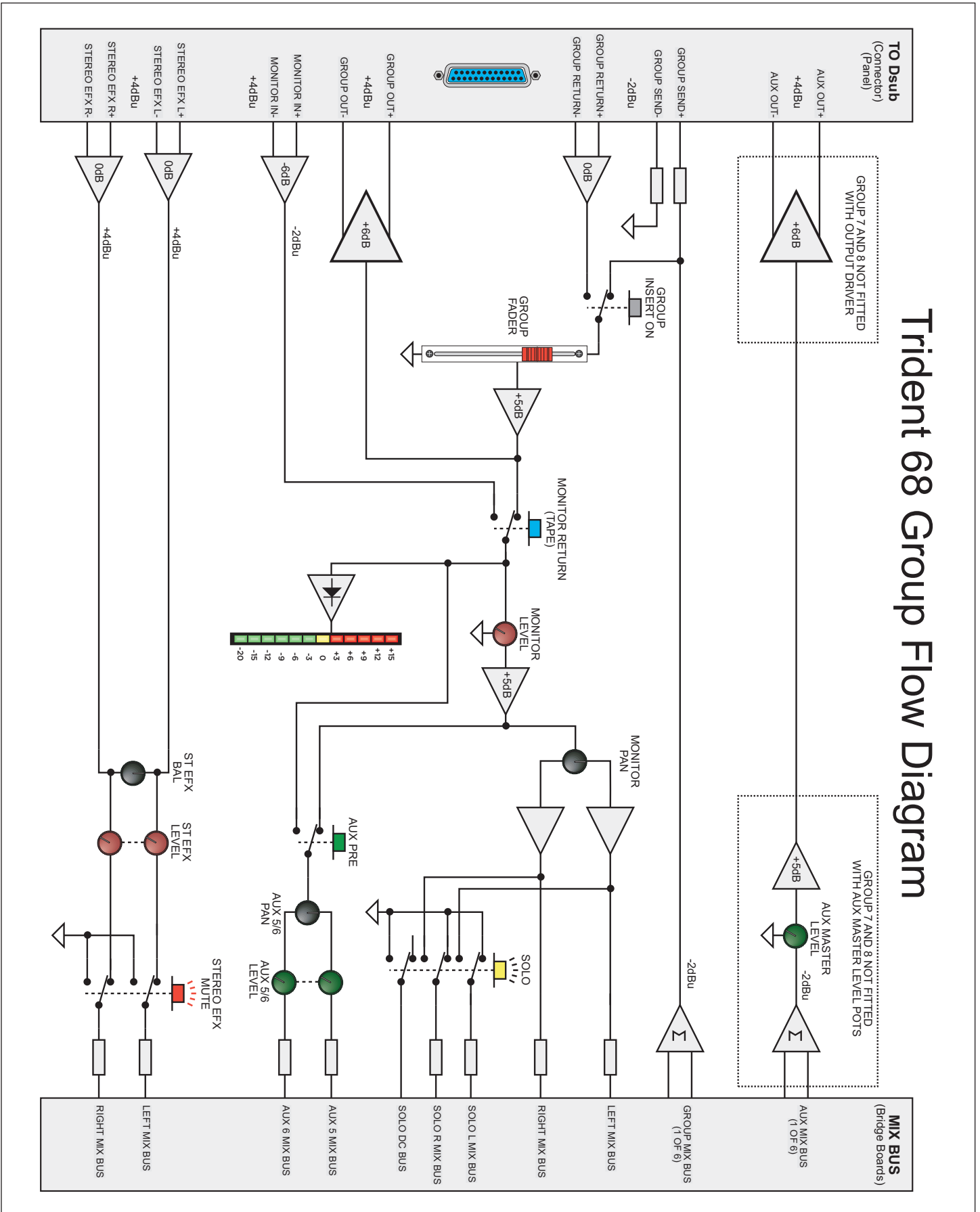

Trident 68 Master Module Flow Diagram

Trident 68 Master Flow Diagram

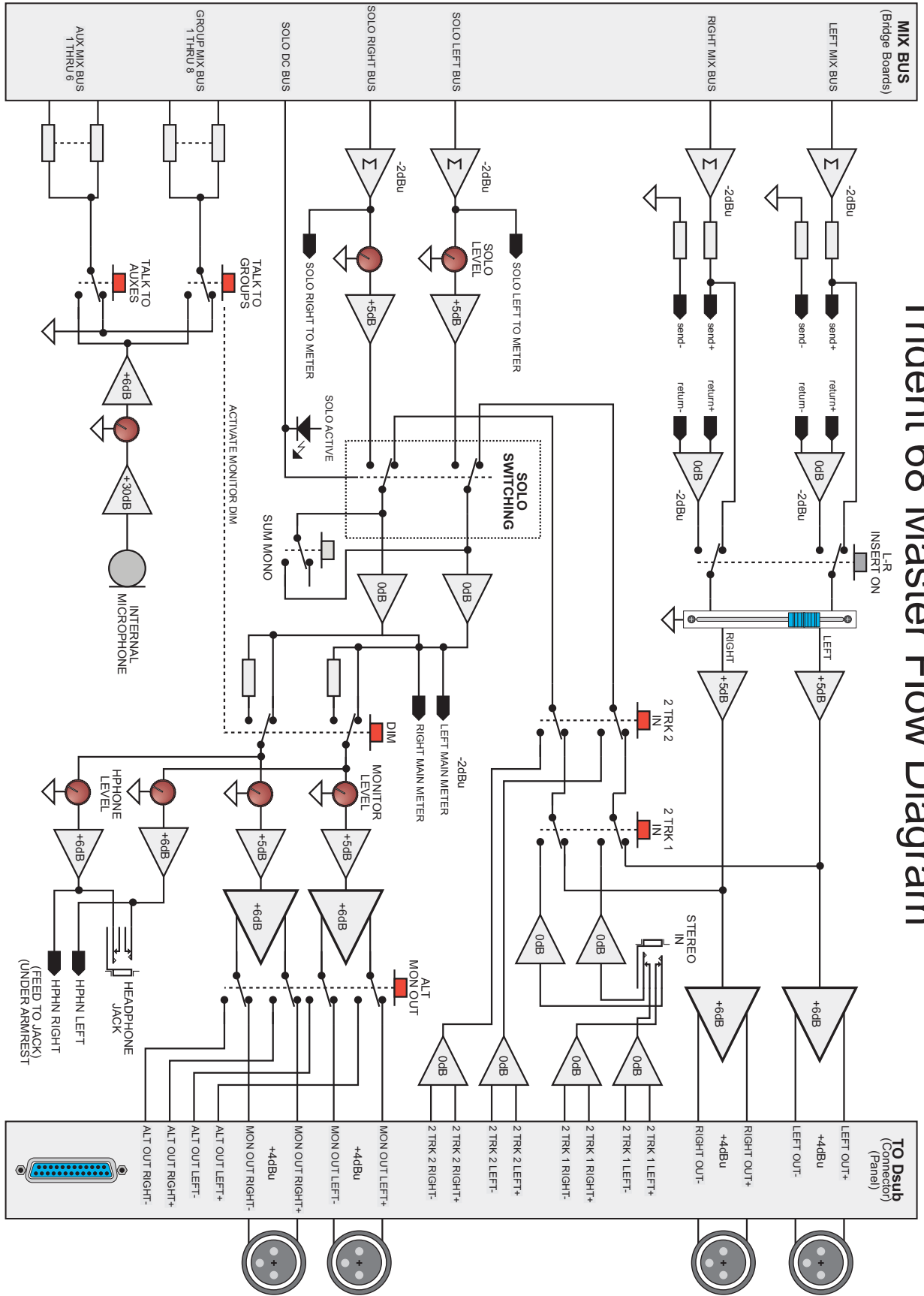

Trident 68 Warning & Policies



CAUTION
RISK OF ELECTRIC SHOCK
DO NOT OPEN



CAUTION: TO REDUCE THE RISK OF ELECTRICAL SHOCK, DO NOT REMOVE COVER. NO-USER SERVICEABLE.



The lightning flash with arrowhead symbol, within equilateral triangle, is intended to alert the user to the presence of uninsulated “dangerous voltage” within the product’s enclosure that may be of sufficient magnitude to constitute a risk of electric shock to persons.



The exclamation point within an equilateral triangle is intended to alert the user to the presence of important, operating and maintenance (servicing) instructions in the literature accompanying the appliance accordance with manufacturers’ instructions.

WARNING: TO AVOID FIRE OR ELECTRIC SHOCK HAZARD, DO NOT EXPOSE THIS APPARATUS TO WATER, RAIN OR MOISTURE.

NOTE: This apparatus does not exceed the Class A/Class B (whichever is applicable) limits for radio noise emissions from digital apparatus as set out in the radio interference regulations of the Canadian Department of Communications.

ATTENTION: Le présent appareil numérique n’émet pas de bruits radioélectriques dépassant les limites applicables aux appareils numériques de class A/de class B (selon le cas) prescrites dans le règlement sur le brouillage radioélectrique édicté par les ministères des communications du Canada.

These limits are designed to provide reasonable protection against harmful interference in a commercial/residential installation respectively. This equipment generates, uses, and can reduce radio frequency energy, and, if not installed and used in accordance with the instruction manual, may cause harmful interference to radio communications. There is no guarantee that interference will not occur in a particular installation.

If this equipment does not cause interference to radio or television equipment reception, which can be determined by turning the equipment off and on, the user is encouraged to try to correct the interference by any combination of the following measures: (1) Relocate or reorient the receiving antenna, (2) Increase the separation between the equipment and the receiver, (3) Plug the equipment into an outlet on a technician for additional assistance.

CAUTION: Changes or modifications to this equipment not expressly approved by the party responsible for compliance could void the user’s authority to operate this equipment.

**RoHS
COMPLIANT**



**UK
CA**

STATEMENT OF COMPLIANCE RoHS COMPLIANCE: Trident Audio Developments manufactures complete electronic products which are covered by the European Union’s “Removal of Hazardous Substances” directive 2002/95/EC (RoHS). This directive seeks to eliminate toxic substances from the manufacturing process, such that when equipment is disposed of at the end of its life cycle, the materials it contains do not contaminate the environment and pose health risks. Banned substances are lead, mercury, cadmium, hexavalent chromium, polybrominated biphenyls (PBB) and polybrominated diphenyl ethers (PBDE).

Lead is used together with tin in solder connections to reduce the melting point of solder. Lead-free solder requires higher soldering temperatures which in turn places greater thermal stress on components.

Trident Audio Developments takes seriously its obligations under the RoHS directive and insists that its factories use only components that are certified RoHS compliant, as well as lead-free solder. In a very few cases the necessary components may not yet be available to the world market but we work continuously to eliminate any such exceptions at the earliest opportunity. Our printed circuit boards (PCB’s) and all soldered joints have been lead-free since 2005.



STATEMENT OF WEEE POLICY: Trident Audio Developments manufactures many complete electronic products which are covered by the European Union’s “Waste Electric and Electronic Equipment” directive 2002/95/EC (WEEE). This directive seeks to ensure that waste electric and electronic equipment is disposed of in an environmentally responsible manner, at the end of its life cycle. Trident Audio Developments take seriously its obligations under this directive to take back WEEE-affected products and, from 13th August 2005, will mark all such products with the crossed-out wheeled bin symbol.

Business to business products: Trident Audio Developments will cost neutrally take back WEEE-affected electric and electronic equipment in this category, from 1st January 2006. Trident Audio Developments will work with disposal and recycling partners working within the EU. The waste electric and electronic equipment can be turned over to a disposal and recycling companies in the countries concerned.

Business to customer products: emerging electric and electronic equipment will be disposed of by local authorities’ collection systems. Dual use products: this equipment will be disposed of by local authorities’ collection systems.

STATEMENT OF UKCA COMPLIANCE: Trident Audio Developments hereby declares its commitment to complying with the United Kingdom Conformity Assessment (UKCA) marking requirements for the electronic products we manufacture. As of January 1, 2021, the UKCA marking has become a mandatory requirement for products placed on the market in Great Britain. We have undertaken a thorough assessment of our products to ensure they conform to the relevant UKCA standards and regulations, and we are committed to maintaining this compliance.

Trident 68 Fader Care and Maintenance

Level 1

The first step is to use compressed air to blow as much dirt as possible out of the fader.

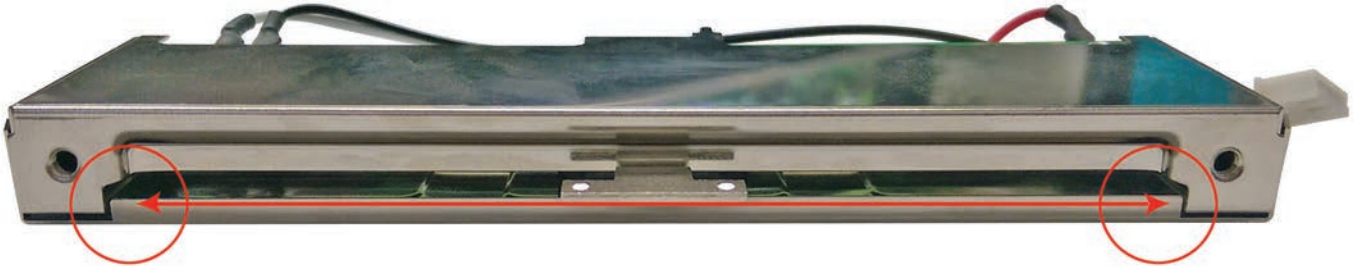

Figure 1: Start by blowing one end, and then the other. There is usually dust or debris in the fader that will come out easily, and this usually would be all that is needed in terms of cleaning. Move the fader carriage to one end and blow air into the slot aiming away from the carriage so that dust can escape through the slot. Then move the carriage to the opposite end and blow air aiming the opposite way.

Using off the shelf cleaner/lube spray on the fader can actually worsen its condition, and it's likely that the dust and debris will be matted down and stick in the corners. This is not recommended for service. A fader might seem to work better for a while using a cleaner/lube spray, but this won't last and might lead to the need for a more substantial (and time consuming) cleaning effort.

Note: Compressed air must be clean and dry. If an air compressor isn't available, cans of aero-duster will work, but they don't last long

Level 2

If the initial "blowing out" process didn't offer the desired results, it's time to move on to use of chemical contact cleaner. Some faders have lubricating grease applied by the manufacturer, while others employ a self-lubricating Teflon-type of plastic. If used sparingly, chemical contact cleaner shouldn't impact the self-lubricating type, but it will invariably wash away lubricating grease. The goal is to avoid adding any more lubrication than is absolutely necessary - dust tends to fall away from dry surfaces, but it sticks to oily surfaces.

After spraying contact cleaner, exercise the fader and then quickly blow out the excess cleaner. This helps to spread the cleaner over the entire fader surface, while the excess cleaner carries away additional loosened dirt.

Level 3

The fader is still feeling a little rough?

Time to try a little lubrication. The key word is "little" - use as little as possible. Depending on the type of fader, use a precision dropper to place just a few drops of lubrication in the fader, or give it just a quick squirt. Exercise the fader and then blow away the excess with compressed air.

Some oils react with plastic, causing it to break down. If there's any doubt, test it out on a spare fader first before applying. Be careful not to damage the wiper, which can ruin the fader.

Certain faders use thicker grease that results in a "smoother" feel, and these may actually feel too loose after lubrication. If this proves bothersome, use silicon or petroleum grease. Proper maintenance will keep faders performing well for years and is essential to their longevity.

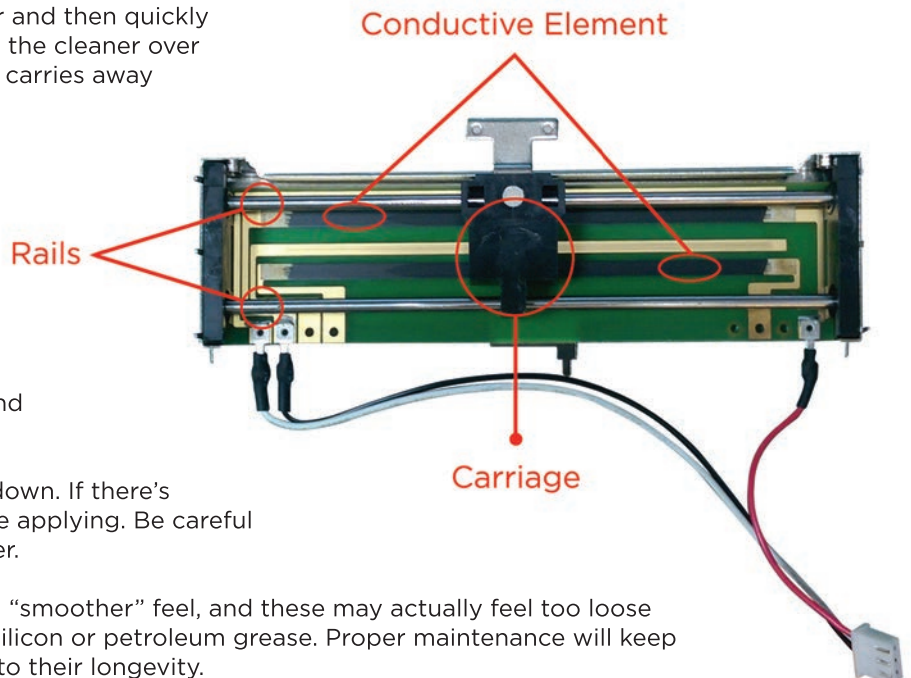

Trident Audio Developments

US Sales & Service +1 (310) 323-9050
sales@tridentaudiodevelopments.com

UK Service Only

ukservice@tridentaudiodevelopments.com
tridentaudiodevelopments.com

